

# Making Large UPS Systems More Efficient

By Victor Avelar

White Paper #108

**APC**<sup>®</sup>  
Legendary Reliability<sup>®</sup>

## Executive Summary

As energy resources become more scarce and more expensive, electrical efficiency is becoming a more important performance factor in the specification and selection of large UPS systems. There are three subtle but significant factors that can materially affect a company's cost of operating a UPS system and particularly the electrical bill. Unfortunately, the people who specify systems often fail to recognize these factors, which leads to increased costs to the owner because operational efficiencies are not correctly considered. This paper discusses the common errors and misunderstandings in evaluating UPS efficiency. UPS efficiency curves are explained, compared, and their cost implications quantified.

# Introduction

The traditional approach to the specification and selection of UPS systems has focused almost solely on system reliability, as represented by the mean time between failure (MTBF) provided by manufacturers and consulting engineers. Two issues are now conspiring to move efficiency, as much as reliability, to the forefront in UPS evaluation: (1) a focus on total cost of ownership (TCO) over the lifetime of the system, and (2) public and private environmental initiatives, as exemplified by “green building” certification programs and demand-side management programs offered by utility companies.

There are two major contributors to UPS inefficiency: the inherent losses of the UPS modules themselves, and how the system is implemented (i.e. right-sizing, redundancy). Oftentimes, when specifying UPS systems, the only efficiency value considered is the best case value published by manufacturers. This is misleading and will be explained further.

A hypothetical example is perhaps the best way to demonstrate how this practice can have a material effect on a company’s electrical expense. Consider two 1 MW UPS systems from two different manufacturers. UPS system 1 and UPS system 2 have identical published efficiencies (93% at full load), are operated in a 2N architecture, use an electrical cost of \$0.10 / kW hr, and support a 300 kW load. Many would argue that there would be no difference in the annual electrical cost of operating these two systems. This is a flawed statement except for emergency or maintenance scenarios, UPSs are never operated at a 100% load level in a 2N configuration since each side of the “N” has to be capable of supporting the full load if one side fails. Therefore, the maximum design load on each UPS in normal operation cannot exceed 50%. In reality 2N systems rarely achieve even 50% load on each system. Some field surveys indicate that 2N data centers operate at 20-40% of their 2N capacity.<sup>1</sup> For this example, a typical 30% load is assumed, where each UPS supports 150 kW. Each UPS in system 1 incurs an annual electrical cost of \$10,470 in power losses vs. \$28,322 for each UPS in system 2. Since there are two UPSs in each system, the electrical losses are doubled to \$20,940 and \$56,644 per year, respectively. These UPS losses manifest themselves as heat which must be removed by the cooling system. Assuming each kW of heat requires 400 watts for the cooling system to remove it, an additional \$8,376 vs. \$22,651 per year is required<sup>2</sup>. In this example, a typical data center lifespan of 10 years, results in a total cost of UPS system losses of \$293,165 vs. \$793,021 as shown in **Table 1**. So, how is it that the electrical losses between two seemingly identical UPS systems can differ by almost a factor of three?

*Table 1 – Two different systems at the same load in a 2N architecture incur different costs*

| UPS System   | UPS Loss Cost | Cooling Cost | Annual Cost of Inefficiency | 10 Year Cost of Inefficiency |
|--------------|---------------|--------------|-----------------------------|------------------------------|
| UPS System 1 | \$20,940      | \$8,376      | \$29,317                    | \$293,165                    |
| UPS System 2 | \$56,644      | \$22,651     | \$79,302                    | \$793,021                    |

<sup>1</sup> A typical UPS load in a data center is about 30% as discussed in APC White Paper #37, “Avoiding Costs From Oversizing Data Center and Network Room Infrastructure”.

<sup>2</sup> 400 watts is a conservative estimate for the actual cost of cooling a data center. According to the following report the estimated cooling kW represented 51% of the total data center heat load: Jennifer Mitchell-Jackson, *Energy Needs in an Internet Economy: A Closer Look at Data Centers*, July 10, 2001, p. 35-37.

The answer lies in the efficiency curves of both UPS systems and how they are sized against the load. An improvement of 5 percentage points in the efficiency of a single UPS can result in an electrical cost reduction between 18% and 84% depending on how much load is on the UPS. This is illustrated later using two UPS designs currently on the market.

In order to meet today's efficiency and environmental demands, UPS manufacturers can utilize three factors to improve the efficiency of large UPS: **technology**, **topology**, and **modularity**. Together these factors can reduce the electrical UPS losses in the form of heat energy (kW). This paper explains the efficiency curve and will discuss common errors made in evaluating UPS efficiency. It will show how technology, topology, and modularity allow manufacturers to improve UPS efficiency. For a discussion on full data center efficiency see APC White Paper #113, "Electrical Efficiency Modeling for Data Centers".

## UPS Efficiency Curve

If there is only one UPS efficiency number listed on a UPS data sheet, it is almost certainly quoted at 100% load (rated load) and at various other favorable system states such as fully charged batteries, nominal UPS input voltage, and optional input transformers and filters disconnected or not installed. The fact is that most UPS manufacturers quote UPS efficiency at 100% load because it represents the very best efficiency the UPS will attain. **Unfortunately, very few customers will ever reap the benefits of this efficiency because they will never reach 100% load.** Specifying a UPS based on its nameplate efficiency is like buying a car that gets maximum fuel efficiency on the highway and using it for city driving. A better way to specify a UPS is to use the efficiency at approximately 30% load which tends to be the average load most medium to large scale data centers operate at. To do this one must first understand what a UPS efficiency curve is and how it is created.

**Figure 1** shows the basic shape of a UPS efficiency curve. The highest point on the curve corresponds with the highest efficiency (Y axis) and the highest load level (X axis). In this curve, the maximum UPS efficiency is 93%. In order to specify a UPS at a realistic load level, the customer must find or test the UPS efficiency at a common load level such as 30%, which on this curve is 89%. In cases where a data center uses redundant UPSs (2N), the efficiency drops even more due to the fact that the load is split across both UPSs which would bring the efficiency down to 82%. This redundancy effect is discussed later in the paper.

### How a UPS efficiency curve is created

An efficiency curve is created by first measuring the power supplied to the UPS (input) and the power the UPS supplies to the load (output). These measurements are taken at various loads usually at 25%, 50%, 75%, and 100%. A measurement is also taken at 0% load to find out how much power the UPS itself draws (no-load loss). From these measurements the losses are calculated by subtracting the input power from the output power. These losses are then plotted on a graph and a trend line is fitted to these points. The trend line provides a formula from which all the other points can be plotted for every load percentage. With all of the power losses calculated, the efficiency curve is then created by plotting the ratio of output to input power with respect to load level.

Figure 1 – UPS efficiency curve

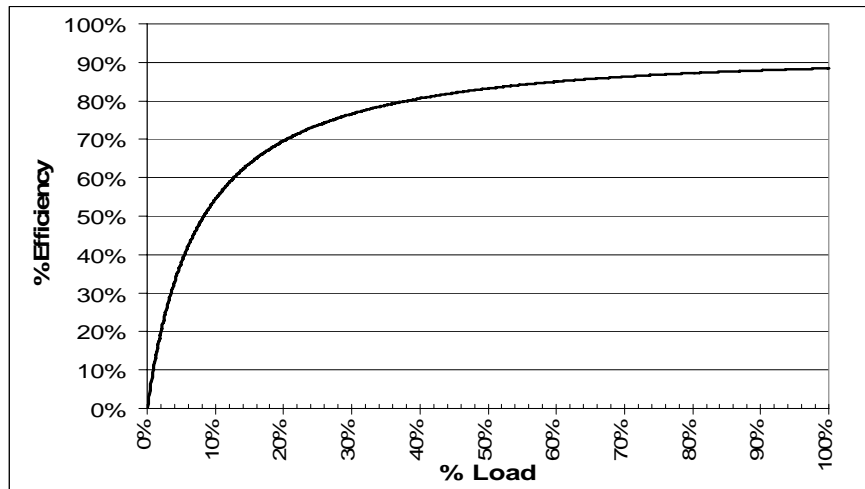
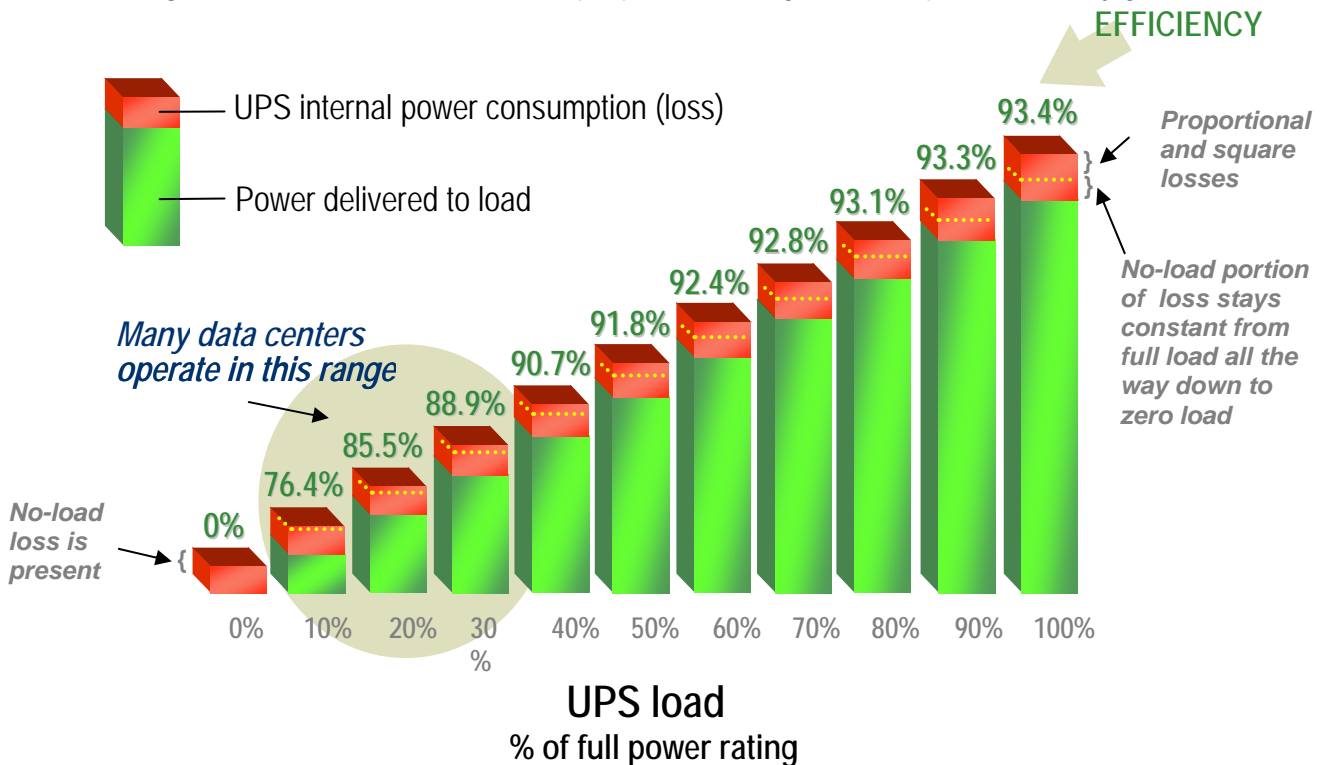

Figure 2 helps to better understand the efficiency curve in Figure 1 by identifying where all the power is going.

Figure 2 – Breakdown of total UPS input power showing where the power ultimately goes



In the figure, the green bars represent all the power going to the IT loads while the red bars represent internal UPS losses that define the efficiency curve in Figure 1. If a UPS had perfect efficiency, all the power supplied to the UPS would be delivered to the data center loads resulting in completely green bars (no losses) for all load levels. In this case, the efficiency “curve” would look like a horizontal line (100% for all

loads). However, as indicated by the red bars, some of the input power is used directly by the UPS. There are three types of UPS losses: “no-load” losses, “proportional” losses and “square-law” losses.

### No-load losses

At 0% load, all the input power is used by the UPS, hence the name “no-load” losses. This may also be called other names such as tare, constant, fixed, shunt, and parallel. These losses are independent of load and are attributed to powering such things as transformers, capacitors, logic boards, and communication cards. No-load losses can represent over 40% of all UPS losses and are by far the largest opportunity for improving UPS efficiency. This is discussed in more detail in the appendix.

### Proportional losses

As more load is added to a UPS, a larger amount of power must be “processed” by various components in its power path. For example, the switching losses from transistors, and the resistance losses from capacitors and inductors, all add to proportional losses.

### Square-law losses

As more load is added to a UPS, the electrical current running through its components increases. This causes losses in the UPS with the square of the current sometimes referred to as “I-squared R” losses. The power losses dissipated in the form of heat are proportional to the square of the current. Square-law losses become significant (1-4%) at higher UPS loads.

The very nature of comparing the efficiencies of two or more UPSs means that only their losses (the red bars in **Figure 2**) are evaluated. An efficiency curve alone can tell a great deal about a UPS including quantifying its proportional, no-load, and square-law losses across all load levels. Plotting these three types of losses relative to UPS load percentage will produce a power loss graph similar to that of **Figure 3**. Notice how the no-load loss remains constant through the entire load spectrum while the proportional loss ramps up as more IT equipment is plugged into the UPS.

Figure 3 – Power loss graph

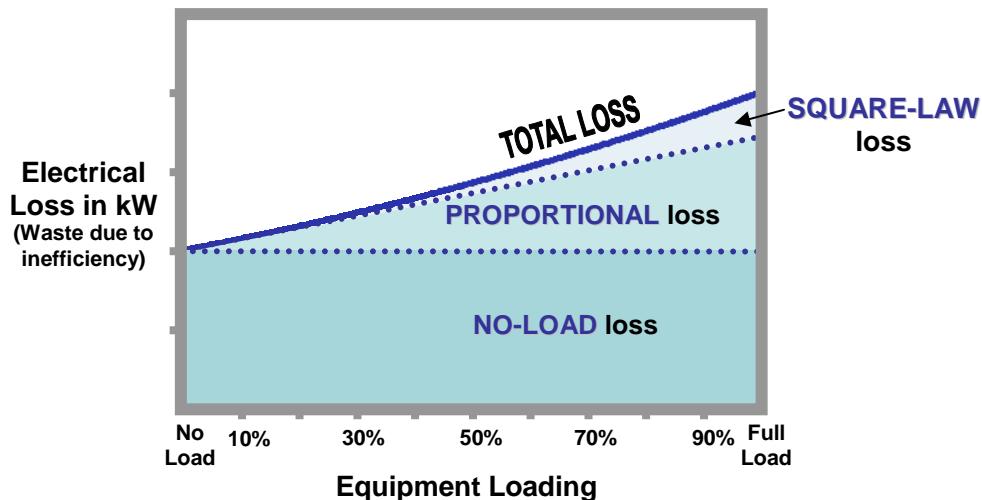

## Common mistakes made in specifying UPS systems

It is very easy for those who specify UPS systems to dismiss the efficiency improvement of one UPS over another. **Table 2** lists the various reasons and why they are flawed.

*Table 2 – Reasons for dismissing UPS efficiency*

| Reason                                                                                                                                                                | Flaw                                                                                                                                                                                                                                                                                         |
|-----------------------------------------------------------------------------------------------------------------------------------------------------------------------|----------------------------------------------------------------------------------------------------------------------------------------------------------------------------------------------------------------------------------------------------------------------------------------------|
| Published UPS efficiencies are almost always quoted at 100% load under the most favorable conditions leading to nearly identical efficiencies between different UPSs. | Quoted efficiencies should only be considered when the UPS will be loaded greater than 80% on day one. Otherwise, the efficiency at the lower load should be used for UPS specification. Furthermore, manufacturers often exclude input filters that decrease quoted efficiencies by 0.5-1%. |
| When a UPS is loaded above 80%, the electrical cost of UPS losses represents a small percentage compared to the cost of powering the IT load.                         | Although this is true, the actual dollar savings between one UPS and another can nevertheless be quite large.                                                                                                                                                                                |
| The published efficiencies for the UPSs being compared are used to calculate electrical losses for all load scenarios resulting in similar costs.                     | Although efficiency appears constant above 30% load, it does drop slightly and drops significantly below a 20-30% load level. Furthermore, a small difference in efficiency translates into a larger than expected energy cost difference.                                                   |
| Cost calculations are performed on an annual basis resulting in minor costs.                                                                                          | Seemingly small annual costs are off by a factor of 10. Cost calculations should assume the life of the data center which is typically 10 years.                                                                                                                                             |

A business pays for the electricity that is measured by the utility meter – This is the ultimate benchmark for the specification of any equipment. This is why manufacturers' efficiency curve data should be based on realistic customer installations. Furthermore, the design of a data center power system should comprehend the efficiency impact over the entire power train and not just the UPS. A case in point is the removal of input filters to increase measured UPS efficiency. UPSs by their very nature produce harmonics or unwanted currents that increase heat losses in upstream wiring and transformers thereby decreasing efficiency. UPS input filters minimize these adverse affects by attenuating the harmonic component of the alternating current. By removing input filters to increase measured UPS efficiency, a manufacturer has in essence moved the heat losses and their associated electrical cost further upstream. Ultimately the end user unknowingly pays an efficiency cost penalty more than the 0.5 to 1 percentage points at full load. This is because the UPS is typically loaded at about 30% where the filter's fixed losses weigh more heavily. For example, at \$0.10 / kW hour, assume 1 MW UPS at 30% load has a best case efficiency of 89%. If a filter is added and drops the efficiency by 3 percentage points at that load level, the annual electrical cost increases from \$32,481 to \$42,781, an increase of nearly 32%.

Perhaps the most effective method of specifying a UPS for efficiency is to request an efficiency curve from the manufacturer that will completely describe the energy saving benefits of one UPS over another. Note that the curve should come with input and output power data so that by using a simple spreadsheet, the energy savings can be calculated from 0% to 100% load and every point in between. **It is important that the manufacturer's curve be based on a configuration similar to what is being specified.** The

appendix of this paper provides an in depth discussion on UPS efficiency comparisons by investigating various scenarios. The following section describes how manufacturers can improve UPS efficiency by using various levers of design.

## Improving Large UPS Efficiency

There are three significant losses that a manufacturer can lower in order to improve UPS efficiency; no-load losses, proportional losses, and square-law losses. To do so, manufacturers have three points of leverage at their disposal; **technology**, **topology**, and **modularity**. By understanding how these factors impact efficiency, specifying engineers can better identify UPS systems that will significantly decrease the electrical cost of operating them.

### Technology

The word technology tends to overlap with topology and modularity but in this paper its meaning is constricted to describe only the building blocks of a UPS which include the hardware and software.

#### Switching technology: IGBTs replace SCRs

Large solid state (“static”) UPS systems work by converting alternating current (AC) to direct current (DC) and DC to AC. Part of this process of power conversion is rapid on-off switching which leads to power losses in the form of heat across the switch due to its inherent electrical resistance. In fact, even when a switch is open, there is always some small amount of heat loss due to leakage current. This is analogous to the heat generated when a rope (current) is pulled quickly through a person’s hands (switch). When the rope is held tightly (switch closed) heat is generated, when the rope is held loosely (switch open) very little heat is generated.

Originally, the switching process was accomplished by silicon-controlled rectifiers (SCRs) which had high-power / high-voltage switching capabilities. SCRs were standard UPS components until the mid 1990s and are still in use today in some older designs. They were relatively inexpensive and easy to design around, but had serious drawbacks: worst was they tended to fail “short,” which produced a short circuit at the most critical point of the UPS – the DC bus. Protective circuits and devices had to be added to protect the DC bus from this failure mode – which, in turn, lead to even more components that could (and would) fail. SCRs are easy to turn on (a 1-2 volt signal to the gate will do it) but difficult to turn off (a reverse-bias voltage spike is necessary). Transistors do not have this problem – they require less power to turn on and off. Essentially they are “on” when the gate signal is present, and “off” when it is not – but until the mid 1990s, they were limited in current-handling capabilities. This was solved when isolated gate bipolar transistors (IGBTs) were introduced. Capable of higher speeds and higher power handling, IGBTs enabled the power conversion process to be operated in a “high frequency pulse-width-modulation (PWM)” mode. High frequency PWM reduces the size of filter components required which leads to further efficiency improvements.



## Controls: DSP replacing Analog

Many manufacturers today are moving from analog controls to digital signal processing (DSP) controls. This is analogous to switching from a traditional watch with gears and hands to a digital watch with a battery and liquid crystal display (LCD). DSP controls are much more intelligent, can operate at much faster rates, and therefore make many more decisions that help to improve efficiency. DSP controls also reduce the number of components compared to analog circuits.

More advanced DSP controls can improve efficiency through intelligent adaptive switching, where the main high frequency power switches can maintain output voltage precision with fewer loss-prone switching transitions. For lighter loads, the reduction in switching transitions using DSP can be up to 50%, resulting in significant improvements in efficiency. In addition, DSP controls require much less power than prior generation controls, which allows a substantial reduction in no-load losses.

IGBT and DSP technologies are major technological improvements which have led to increased UPS efficiency in the most recent generation of UPS products.

## Topology

UPS topology basically defines how their power components are internally connected. Manufacturers can use topology as a tool to reduce the losses for a particular application or size range. There are two principal topologies used in large UPS systems: Double conversion on-line and Delta conversion on-line. In the case of high-power UPS systems (over 200 kVA); a recent publication by the US Electrical Power Research Institute found that *delta conversion on-line* UPS topology currently offers the greatest efficiency<sup>3</sup> (**Figure 4**). The effect of topology on UPS efficiency is explained in the following paragraphs.

*Figure 4 – Excerpt from EPRI UPS report (pg. 20)*

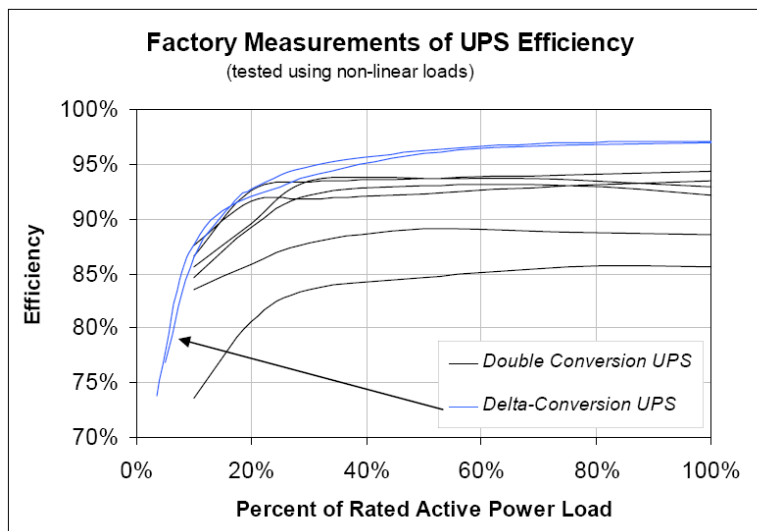

<sup>3</sup> My Ton, Brian Fortenbury, *High Performance Buildings: Data Centers Uninterruptible Power Supplies (UPS)*, p. 20. [http://hightech.lbl.gov/documents/UPS/Final\\_UPS\\_Report.pdf](http://hightech.lbl.gov/documents/UPS/Final_UPS_Report.pdf) (accessed April 28, 2006).

**Figure 5 – Two “on-line” UPS power conversion technologies**

From APC White Paper #1, “The Different Types of UPS Systems”

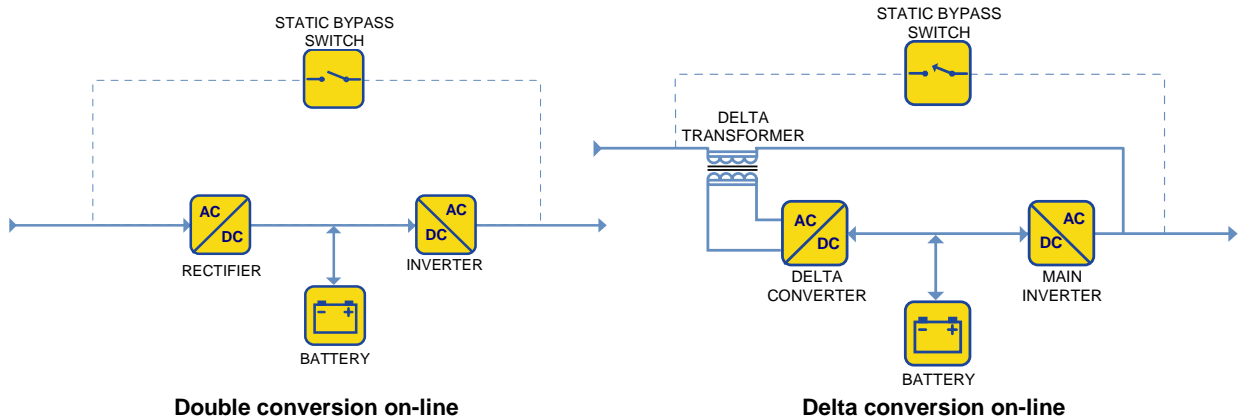

In the case of delta conversion on-line systems, efficiency is improved mainly by reducing no-load losses, but also by a reduction in square-law losses. By using the input transformer in a series arrangement, the UPS input current and UPS output voltage can be fully regulated and controlled without having to convert all incoming power to DC and back to AC again, as is done in a double conversion on-line system. This is shown in **Figure 5**. Note that the output voltage in the delta conversion on-line UPS is fully regenerated by the output inverter and isolated from the utility supply just like it is in a double conversion on-line UPS. Another example of how topology reduces no-load losses is by eliminating the input filter associated with double-conversion topology. Traditional double conversion UPSs generate high input harmonic current (from 9% to 30% total harmonic distortion) and low power factor (0.9 to 0.8). For this reason, an input filter is added to double conversion designs, which increases the power factor, and minimizes harmonics or unwanted current that increases heat losses in upstream wiring and transformers. Note, however, that adding this input filter interferes with engine generator voltage regulation. By drawing sinusoidal current, delta conversion topology generates negligible input harmonic current (less than 3%) with a unity power factor, thus eliminating the need for an input filter altogether. For more discussion on differences in UPS topologies, see APC White Paper #1 “The Different Types of UPS Systems”.

Delta conversion is a good illustration of how topology can be used by manufacturers to increase UPS efficiency and drive up energy savings, with no compromise in electrical performance. The following comparison helps illustrate this savings.

**Quantifying the topology effect**

1N Topology Comparison – Delta Conversion vs. Double Conversion

Configuration “A” is a 1 MW delta conversion on-line UPS. Configuration “B” is a 1 MW double conversion on-line UPS. **Figure 6** shows the efficiency curves, as a function of percent load, for each UPS. In both cases, the load is assumed to be 300 kW. The efficiency of configuration “A” at 30% load is 94.9% versus

88.7% for configuration “B”. This represents a difference of 6.2 percentage points in efficiency, which is a significant cost savings over the life of the UPS.

*Figure 6 – Efficiency curves for delta conversion UPS “A” and double conversion UPS “B”*

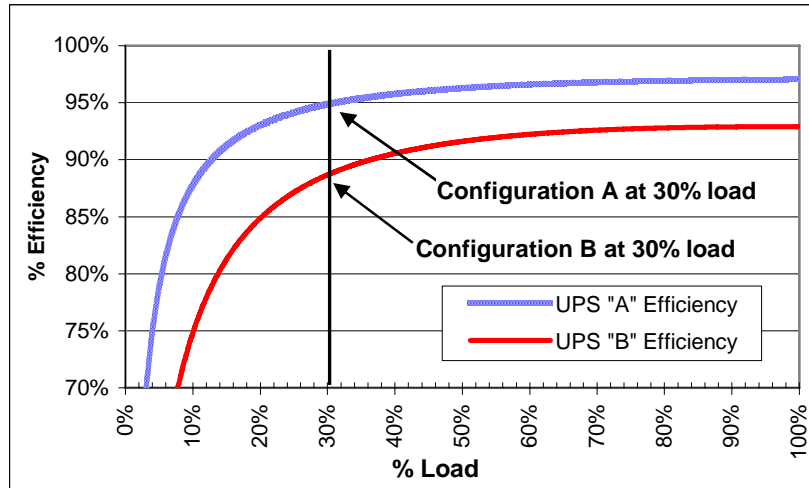

**Table 3** illustrates a 58% costs savings associated with the delta conversion topology of configuration “A” versus the double-conversion topology of configuration “B”. It should be obvious that the largest contributor to cost for either UPS comes from the no-load losses which represent about 60% of all losses.

*Table 3 – 10 year efficiency cost analysis for a 300 kW load – Delta conversion vs. Double conversion (1N)*

| UPS System                            | Efficiency % | Proportional Loss | No-load Loss | Square-law Loss | Cooling Cost | Total Cost of Inefficiency | 10 Year % Cost Savings         |
|---------------------------------------|--------------|-------------------|--------------|-----------------|--------------|----------------------------|--------------------------------|
| Configuration “A” – Delta conversion  | 94.9%        | \$16,820          | \$116,771    | \$8,523         | \$56,846     | \$198,960                  | <b>\$271,091</b><br><b>58%</b> |
| Configuration “B” – Double conversion | 88.7%        | \$25,213          | \$283,298    | \$27,239        | \$134,300    | \$470,051                  |                                |

The costs presented in **Table 3** nearly double when the same UPSs are analyzed as a redundant 2N architecture (system plus system). The following comparison illustrates this.

2N Topology Comparison – Delta Conversion vs. Double Conversion

Configuration “A” consists of redundant (2N) 1 MW delta conversion on-line UPS systems. Configuration “B” consists of redundant (2N) 1 MW double conversion on-line UPS systems. The load is again assumed to be 300 kW. This means that each UPS is now loaded to only 15% since the two UPSs in each configuration carry half of the load in normal operation. **Table 4** describes the cost breakdown of this 2N scenario. Note that for any particular UPS, although the square-law losses are halved in a 2N architecture, it doesn’t offset the doubling of the no-load losses since these kW losses are independent of the load.

*Table 4 – 10 year efficiency cost analysis for a 300 kW load – Delta conversion vs. Double conversion (2N redundancy)*

| UPS System                            | Efficiency % | Proportional Loss | No-load Loss | Square-law Loss | Cooling Cost | Total Cost of Inefficiency | 10 Year % Cost Savings |
|---------------------------------------|--------------|-------------------|--------------|-----------------|--------------|----------------------------|------------------------|
| Configuration "A" – Delta conversion  | 91.2%        | \$16,820          | \$233,542    | \$4,262         | \$101,849    | \$356,473                  | \$491,129<br>58%       |
| Configuration "B" – Double conversion | 81.3%        | \$25,213          | \$566,597    | \$13,620        | \$242,172    | \$847,601                  |                        |

## Modularity

Modularity is the third lever manufacturers can use to decrease energy waste. As illustrated in the efficiency curve of **Figure 5**, the closer a UPS operates to its full load capacity, the more efficient it will be. Modularity allows users to size the UPS system as closely to the load as practicable (in other words, it allows the UPS to operate as far right on the curve as possible). A highly effective way to match capacity to load is easily illustrated by a familiar piece of equipment in the data center – the blade server (**Figure 7**).

*Figure 7 – A modular, scalable blade server*

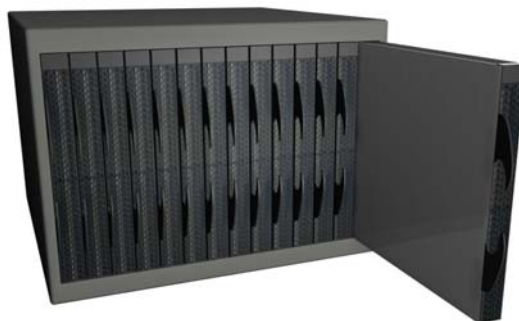

The blade server's architecture illustrates two key design attributes that can be used to advantage in UPS systems: it is **modular**, and it is **scalable**.

A blade server is modular in that a customer buys the frame for the blade servers and then installs standard "blades" in the frame to achieve the amount of processing required for the application. As more blades are inserted into the frame, it becomes a more powerful computing device. This yields a "scalable" system that can be sized depending on computing needs.

Now, imagine a UPS system that uses modular power components in the same way. For example, suppose a UPS chassis was capable of 1 MW of power output and as the load increased on the UPS system, standardized power modules could be added to the system to match the desired output capacity. The UPS could scale from 200 kW up to 1 MW in incremental steps as additional power capacity is needed. The result is that overspending in capital is avoided – you only buy the power components you need – and the UPS is

working at a higher load level because the capacity of the system is more closely matched to the actual load, which results in higher electrical efficiency. The following comparison helps illustrate this right-sizing efficiency benefit for the same 300 kW load used in the previous examples.

**Quantifying the modularity effect**

1N Modularity Comparison – Right-sized UPS vs. Oversized UPS

Configuration “A” is a 1 MW scalable delta conversion on-line UPS that is right-sized with (2) 200 kW modules (400 kW). Configuration “B” is the same exact UPS, but oversized to 1 MW with (5) 200 kW modules. The efficiency curve for this comparison is illustrated in **Figure 8**<sup>4</sup>.

*Figure 8 – Efficiency curve for 1MW delta conversion UPS*

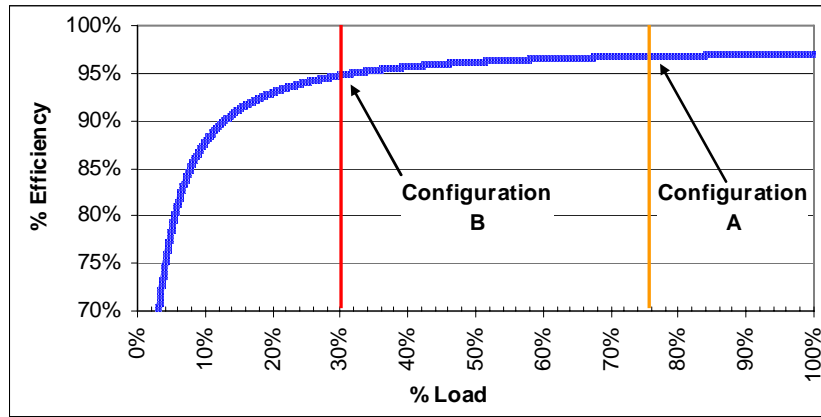

The graph illustrates the two points on the curve where this comparison takes place (75% load and 30% load for configuration A & B respectively). These two points correspond to efficiencies of 96.9% and 94.9% respectively. **Table 5** illustrates the breakdown of the efficiency cost analysis for each case. While proportional losses are equivalent, the no-load losses for the oversized UPS are 2.5 times greater than the right-sized UPS. However, the efficiency gain of right-sizing is slightly reduced by the increase of square-law losses which are 2.5 times greater than the oversized UPS. This is because square-law losses are more pronounced at higher loads.

*Table 5 – 10 year efficiency cost analysis for a 300 kW load – Scalable Delta conversion UPS Right-sized vs. Oversized (1N)*

| UPS System                                   | Efficiency % | Proportional Loss | No-load Loss | Square-law Loss | Cooling Cost | Total Cost of Inefficiency | 10 Year % Cost Savings  |
|----------------------------------------------|--------------|-------------------|--------------|-----------------|--------------|----------------------------|-------------------------|
| Configuration “A” – Right-sized Scalable UPS | 96.9%        | \$16,820          | \$46,708     | \$21,308        | \$33,935     | \$118,772                  | <b>\$80,188<br/>40%</b> |
| Configuration “B” – Oversized Scalable UPS   | 94.9%        | \$16,820          | \$116,771    | \$8,523         | \$56,846     | \$198,960                  |                         |

<sup>4</sup> The efficiency curve of Figure 8 represents the oversized UPS but is an excellent approximation when the UPS is right-sized as well.

The following comparison illustrates how these savings increase further when the designs are redundant.

2N Modularity Comparison – Right-sized UPS vs. Oversized UPS

Configuration “A” is a 2N (system plus system) 1 MW scalable delta conversion on-line UPS system that is right-sized with (2) 200 kW modules (400 kW) in each UPS. Configuration “B” is identical to configuration “A” except that each UPS is oversized to 1 MW with (5) 200 kW modules. **Table 7** illustrates the breakdown of the efficiency cost analysis for each case. The interesting thing to note is that the proportional and no-load loss ratios between both UPSs are identical to the 1N modularity comparison yet the 10 year cost savings jumps to 53%. Again, the square-law losses are the reason for this net decrease because they represent a smaller percentage of total losses at lower loads.

*Table 6 – 10 year efficiency cost analysis for a 300 kW load – Scalable Delta conversion UPS Right-sized vs. Oversized (2N)*

| UPS System                                         | Efficiency % | Proportional Loss | No-load Loss | Square-law Loss | Cooling Cost | Total Cost of Inefficiency | 10 Year % Cost Savings |
|----------------------------------------------------|--------------|-------------------|--------------|-----------------|--------------|----------------------------|------------------------|
| Configuration “A” – Right-sized Scalable UPS at 2N | 95.6%        | \$16,820          | \$93,417     | \$10,654        | \$48,356     | \$169,247                  | \$187,225<br>53%       |
| Configuration “B” – Oversized Scalable UPS at 2N   | 91.2%        | \$16,820          | \$233,542    | \$4,262         | \$101,849    | \$356,473                  |                        |

**Quantifying the effect of topology and modularity**

The efficiency benefits of topology and modularity should be evident based on the previous series of comparisons. But how much more could efficiency improve by combining the benefits of both modularity and topology? The following set of comparisons quantifies this improvement.

1N Topology and Modularity Comparison – Delta conversion Right-sized UPS vs. Double-conversion Oversized UPS

Configuration “A” is a 1 MW delta conversion on-line UPS that is scalable and right-sized with (2) 200 kW modules (400 kW). Configuration “B” is a 1 MW double conversion on-line UPS that is non-scalable and therefore oversized. In both cases, the load is assumed to be 300 kW. The efficiency of configuration “A” at 30% load is 96.9% versus 88.7% for configuration “B”, a difference of 8.2 percentage points.

**Table 7** shows a 75% savings in the cost of inefficiency by using the scalable right-sized delta conversion UPS instead of the non-scalable oversized double conversion UPS. In this 1N architecture the total energy cost of configuration “A” is almost four times that of configuration “B”. Furthermore, the no-load losses for configuration “A” are now reduced to 39% of all losses, nearly half the 60% for configuration “B”. **Figure 9** illustrates the breakdown of electrical costs due to the various losses in a 1N architecture.

*Table 7 – 10 year efficiency cost analysis for a 300 kW load – Delta conversion right-sized vs. Double conversion non-scalable with no redundancy (1N)*

| UPS System                                                       | Efficiency % | Proportional Loss | No-load Loss | Square-law Loss | Cooling Cost | Total Cost of Inefficiency | 10 Year % Cost Savings |
|------------------------------------------------------------------|--------------|-------------------|--------------|-----------------|--------------|----------------------------|------------------------|
| Configuration "A" – Right-sized Scalable Delta conversion UPS    | 96.9%        | \$16,820          | \$46,708     | \$21,308        | \$33,935     | \$118,772                  | \$351,279<br>75%       |
| Configuration "B" – Oversized Non-scalable Double conversion UPS | 88.7%        | \$25,213          | \$283,298    | \$27,239        | \$134,300    | \$470,051                  |                        |

*Figure 9 – 10 year cost breakdown of losses in a 1N architecture*

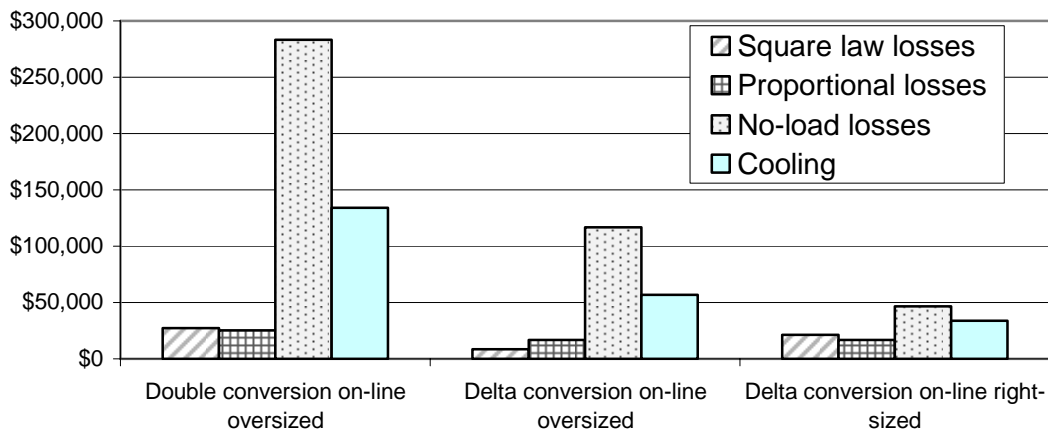

The costs presented in **Table 7** nearly double when configurations "A" and "B" are analyzed as a redundant 2N architecture (system plus system). In a 2N architecture the total energy cost of configuration "B" is almost five times that of configuration "A" as shown in **Table 8**. In looking at **Figure 9** and **Figure 10**, it is clear that the cost impact of no-load losses is greater than all the others. Note that for any particular UPS, although the square-law losses are halved in a 2N architecture, it doesn't offset the doubling of the no-load losses since these losses represent the largest loss at almost all load levels.

*Table 8 – 10 year efficiency cost analysis for a 300 kW load – Delta conversion right-sized v. Double conversion non-scalable with 2N redundancy (system plus system)*

| UPS System                                                       | Efficiency % | Proportional Loss | No-load Loss | Square-law Loss | Cooling Cost | Total Cost of Inefficiency | 10 Year % Cost Savings |
|------------------------------------------------------------------|--------------|-------------------|--------------|-----------------|--------------|----------------------------|------------------------|
| Configuration "A" – Right-sized Scalable Delta conversion UPS    | 95.6%        | \$16,820          | \$93,417     | \$10,654        | \$48,356     | \$169,247                  | \$678,354<br>80%       |
| Configuration "B" – Oversized Non-scalable Double conversion UPS | 81.3%        | \$25,213          | \$566,597    | \$13,620        | \$242,172    | \$847,601                  |                        |



Figure 10 – 10 year cost breakdown of losses in a 2N architecture

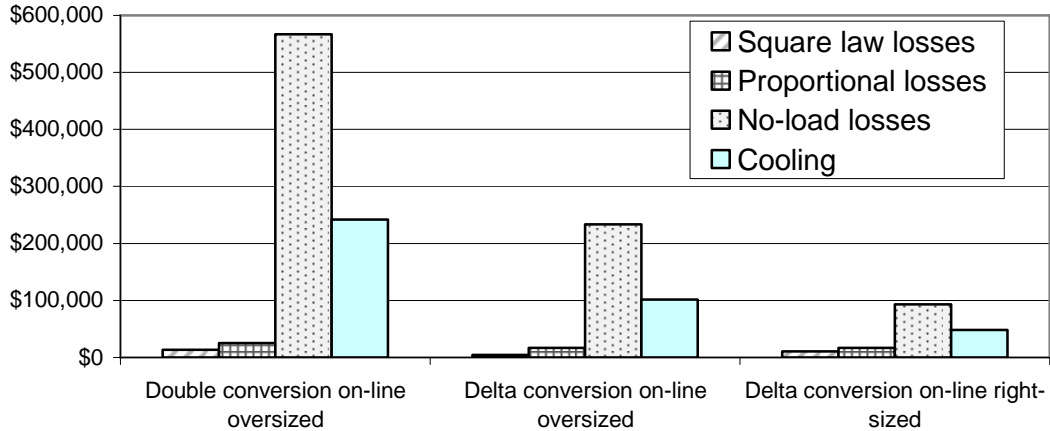

From these comparisons it is clear that increasing UPS efficiency can be accomplished in two ways: by opting for a UPS topology with a higher efficiency and by right-sizing a UPS system. In these examples opting for a higher efficiency topology unmistakably results in the largest efficiency gain. However, this gain requires the purchase of a new UPS which is only realistic in cases where the existing UPS has exceeded its useful life. Alternatively, if right-sizing the UPS system were chosen as a way to increase efficiency, it could result in the purchase of a new UPS but not always. If multiple UPS systems existed, right-sizing could occur by migrating loads over to one or more UPS systems making it possible to turn off the unloaded systems. This right-sizing method is also applied to air conditioning units in oversized data centers.

Figure 11 shows an example of a modular 1 MW UPS scalable in 200 kW increments. The net result is that total cost of ownership (TCO) goes down because there are savings in the capital needed up front, and in the expense of operating the system on a day-to-day basis.

Figure 11 – A modular, scalable UPS system





In addition to higher electrical efficiency from scaling UPS capacity to match the load, modular UPS design has other attributes that contribute significantly to availability, agility, and total cost of ownership. For more about the advantages of modular design, see APC White Paper #116, Standardization and Modularity in Network-Critical Physical Infrastructure.

## Additional Economic Advantages

Increased efficiency has secondary rewards beyond a direct reduction in power consumption. For example in the U.S., the Energy Policy Act of

2005 offers tax incentives for improving the energy efficiency of commercial buildings.<sup>5</sup> Similarly, under the Enhanced Capital Allowances (ECA) scheme, companies in the U.K. can write off 100% of capital spent on qualifying energy efficiency equipment in the first tax year<sup>6</sup>. In some geographic areas (including many areas of the United States), utility companies offer incentives to high-efficiency designs through demand-side management (DSM) programs targeted at reducing overall utility demand. In such programs, efficient users may have their electric rate reduced, or the power company may subsidize the capital cost of more efficient technologies. These benefits further reduce TCO for power-savvy data center owners.

In order to confidently specify energy efficient UPSs, all UPS efficiency measurements must be taken under similar conditions by different vendors and administered and approved by 3<sup>rd</sup> party test agencies. Recently, the Lawrence Berkeley National Laboratory (LBNL) published a report on UPSs as part of their "High-Performance High-Tech Buildings" project focused on improving energy efficiency in data centers as well as cleanrooms and laboratories<sup>7</sup>. In this report an energy efficiency and power quality labeling scheme is proposed for various types of UPS systems as a way of encouraging the use of higher efficiency UPSs.

There are also "green building" designations for high-efficiency designs, which single out efficient data centers as members of a movement that is gaining high credibility in the marketplace. Companies are finding "green" designations to be a corporate plus in their marketing messages, one they can achieve with the added benefit of lowering operating costs. Everyone wins – the company, their customers (through lower

### What You Can Do

- When evaluating UPS systems, consider efficiency as a crucial factor and obtain efficiency curves from manufacturers.
- Understand that *any* UPS is less efficient at lower loading, so make sure manufacturers' efficiency data is shown as a function of loading, not just a single value at full load.
- Choose a modular UPS architecture that allows scaling of UPS capacity to more closely match the actual load. **This will have a significant effect on efficiency.**
- Find out about demand-side management programs that may be offered in your area.
- Investigate the requirements in your area for obtaining a "green building" designation.

<sup>5</sup> <http://www.energy.gov/taxbreaks.htm> (accessed April 28, 2006).

<sup>6</sup> <http://www.eca.gov.uk/etl/page.asp?pageCode=w0002&showHeader=1&showMenu=1> (accessed May 11, 2006).

<sup>7</sup> My Ton and Brian Fortenbury, *High-Performance High-Tech Buildings - Uninterruptible Power Supplies (UPS)*, December 2005.

product costs) and the environment. The green designation will draw increasing market recognition and importance as energy resources become scarcer and more expensive.

## Conclusion

Data centers consume a significant amount of power – a fact largely ignored by the market and by corporations. As total cost of ownership becomes a key decision factor, the differentiating value becomes the *efficiency* of the systems. UPS technologies continue to evolve toward greater electrical efficiency. It is important to remember that the true measure of success (assuming reliability standards are maintained) is the actual efficiency that is achieved, not the details of the internal technology that accomplishes it. New technologies may be invented, old technologies may be improved – but from the user's perspective, it is the efficiency curve that tells the story and, when combined with cost of equipment, provides actionable information. If all systems are equally reliable, as most are, the sound business decision is to employ the most efficient system possible. Contributing to a “green” corporate image, increasing agility, and simplifying service requirements via modular design are additional benefits that underscore the soundness of that choice.

## Related Reading

|                      |                                                                            |
|----------------------|----------------------------------------------------------------------------|
| APC White Paper #1   | The Different Types of UPS Systems                                         |
| APC White Paper #17  | Understanding Power Factor, Crest Factor, and Surge Factor                 |
| APC White Paper #75  | Comparing UPS System Design Configurations                                 |
| APC White Paper #78  | Mean Time Between Failure: Explanation and Standards                       |
| APC White Paper #113 | Electrical Efficiency Modeling of Data Centers                             |
| APC White Paper #116 | Standardization and Modularity in Network-Critical Physical Infrastructure |

### About the Author:

**Victor Avelar** is a Senior Research Analyst at APC. He is responsible for data center design and operations research, and consults with clients on risk assessment and design practices to optimize the availability of their data center environments. Victor holds a Bachelor's degree in Mechanical Engineering from Rensselaer Polytechnic Institute and an MBA from Babson College. He is a member of AFCOM and the American Society for Quality.

# Appendix

## Derivation of costs in Table 3 through 8

This appendix explains how the costs shown in **Tables 3-8** were derived. The following variables were used in the calculations:

Cost per kW hr = \$0.10

Number of hours per year = 8,760 hours

Number of years in operation = 10 years

Energy required by cooling system to remove 1kW of heat = 0.4 kW

Load on UPS for 1N (no redundancy) scenario = 300 kW

Load on each UPS for 2N (system plus system) scenario = 150 kW

The costs in this paper were derived using the curves in **Figure A1**. Both the delta conversion on-line UPS and the double conversion on-line UPS were measured under 100% resistive load by a third party, TÜV Rheinland Group. The delta conversion UPS was rated at 1MVA and the double conversion UPS was rated at 400 kVA. These power loss curves were created by first measuring the power supplied to each UPS (input) and the power each UPS supplied to the load (output). These measurements are taken at multiple load levels including 25%, 50%, 75%, and 100%. A measurement was also taken at 0% load to find out how much power the UPS itself draws (no-load loss). From these measurements the losses were calculated by subtracting the input power from the output power. The losses were then divided by the rated UPS capacity for each UPS which provides a simple way of describing the UPS losses at any load level. (In this analysis the 400 kVA UPS was scaled up to 1 MVA.) These loss percentages were then plotted in Microsoft Excel and a 2<sup>nd</sup> order trend line was added to fit these points with a minimum R<sup>2</sup> value of 0.9998<sup>8</sup>. The trend line provides a formula from which all the other losses can be plotted for every load percentage and are shown below. Plotting 1000 evenly spaced loss percentages with respect load level produced the curve in **Figure A1**.

2<sup>nd</sup> order trend line formula for delta conversion on-line UPS

$$y = 0.01081x^2 + 0.00640x + 0.01333$$

2<sup>nd</sup> order trend line formula for double conversion on-line UPS

$$y = 0.03455x^2 + 0.00959x + 0.03234$$

It is important to note that the first term represents the square-law loss as a percentage of rated UPS capacity. The second term represents the proportional loss and the third term represents the no-load loss. Together they represent a mathematical model for the total UPS losses at any load level.

---

<sup>8</sup> R-squared (R<sup>2</sup>) is a statistical unit from 0 to 1 that indicates how closely the trend line values correlate with the measured values. An R<sup>2</sup> value of 1 indicates a perfect fit or correlation.

Figure A1 – Power loss curves for Delta conversion UPS and Double conversion UPS

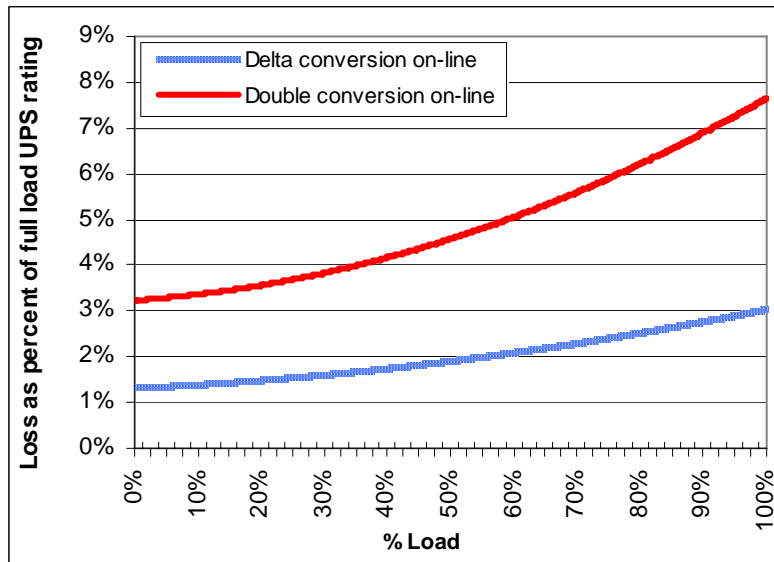

The costs shown in the comparisons are based on the data shown in **Table A1** which was derived from the 2<sup>nd</sup> order equations previously discussed.

Table A1 – Data used in calculations for Tables 3-8

| UPS System                                                   | Load (kW and %) | Proportional Loss % | No-load Loss % | Square-law Loss % | Efficiency % |
|--------------------------------------------------------------|-----------------|---------------------|----------------|-------------------|--------------|
| <b>No Redundancy – 1N</b>                                    |                 |                     |                |                   |              |
| Configuration – Right-sized Scalable Delta conversion UPS    | 300 (75%)       | 0.48%               | 1.33%          | 0.61%             | 96.9%        |
| Configuration – Oversized Scalable Delta conversion UPS      | 300 (30%)       | 0.19%               | 1.33%          | 0.10%             | 94.9%        |
| Configuration – Oversized Non-scalable Double conversion UPS | 300 (30%)       | 0.29%               | 3.23%          | 0.31%             | 88.7%        |
| <b>Redundancy – 2N (system plus system)</b>                  |                 |                     |                |                   |              |
| Configuration – Right-sized Scalable Delta conversion UPS    | 150 (38%)       | 0.48%               | 2.67%          | 0.30%             | 95.6%        |
| Configuration – Oversized Scalable Delta conversion UPS      | 150 (15%)       | 0.19%               | 2.67%          | 0.05%             | 91.2%        |
| Configuration – Oversized Non-scalable Double conversion UPS | 150 (15%)       | 0.29%               | 6.47%          | 0.16%             | 81.3%        |

Note that the loss percentages are with respect to the rated UPS capacity (1000 kW for the oversized UPSs and 400 kW for the right-sized UPS). Although no-load losses (kW) are constant regardless of load

percentage, when stated as a percentage of rated UPS capacity, the percentage increases as the load level decreases.

The following example will help clarify how the loss percentages in the **Table A1** were derived. To calculate the square-law loss percentage at 75% load for “Configuration – Right-sized Scalable Delta conversion UPS”, the delta conversion formula  $y = 0.01081x^2 + 0.00640x + 0.01333$  is used, where “x” is equal to 0.75. However, we are looking for the square-law portion of the losses which is represented by the first term  $0.01081x^2$ . Therefore, the square-law loss is  $0.01081 \times (0.75)^2$  or 0.61% of the rated UPS capacity which in this scenario is 400 kW. This means that at 75% load this right-sized 400 kW UPS produces 2.4 kW of square-law losses.

To calculate the total percentage loss at 75% load for “Configuration “A” – Right-sized Scalable Delta conversion UPS”, the delta conversion formula  $y = 0.01081x^2 + 0.00640x + 0.01333$  is used, where “x” is equal to 0.75. The result is  $y = 0.02421$  or 2.42% of the rated UPS capacity which in this scenario is 400 kW. This means that at 75% load this right-sized 400 kW UPS produces 9.7 kW of losses.

To calculate the 10 year cost of internal UPS losses, the following formula is used:

$$10 \text{ Year Cost of UPS Losses} = \text{LOSS kW} \times 8,760 \times 0.10 \times 10$$

In a 2N architecture, the cost calculated from the equation above must be multiplied by 2 because there are two UPSs producing those losses. In addition to the cost of internal UPS losses, the cooling cost must be added as well. To calculate the 10 year cost of cooling the internal UPS losses, the following formula is used:

$$10 \text{ Year Cost of Cooling UPS Losses} = (10 \text{ Year Cost of UPS Losses}) \times 0.4$$