

Technical Comparison of On-line vs. Line-interactive UPS designs

By Jeffrey Samstad
Michael Hoff

White Paper #79

APC[®]
Legendary Reliability[®]

Executive Summary

UPS systems below 5000VA are available in two basic designs: line-interactive or double-conversion on-line. This paper describes the advantages and disadvantages of each topology and addresses some common misconceptions about real-world application requirements.

Introduction

Most of the factors that go into deciding which UPS to purchase are visible and easily understood: battery back-up time, cost, size, manufacturer, number of outlets, manageability, etc. But there are also less visible factors that are not so easy to understand. One of the least understood, yet most discussed, is **topology**. The topology (internal design) of a UPS affects how it will operate in various environments.

Selecting the right topology can be complicated by claims that certain topologies are superior and absolutely necessary for mission-critical applications. Because these claims typically come from manufacturers trying to sell their so-called “superior” topology, it is difficult to make an informed decision based on such claims alone. The goal of this paper is to speak objectively about the advantages and disadvantages of the two most common topologies: **line-interactive** and **double-conversion on-line**.

At the high and low ends of the power spectrum there is little debate about the relative merits of these two topologies.¹ Above 5000VA, line-interactive has historically been impractical due to its larger size and greater cost. At the low end, below 750VA, double-conversion on-line is rarely considered because other topologies (including line-interactive) are more practical for smaller loads.

Debate regarding double-conversion on-line vs. line-interactive topology usually focuses on the power range between 750VA and 5000VA. This is where the functional and economic advantages of one topology over the other are not so clear and depend upon the particulars of the installation. While line-interactive has become the most commonly manufactured and deployed topology in this power range, advancements in semiconductor technology and manufacturing techniques have brought down the price premium of double-conversion on-line over line-interactive, making the choice between the two harder than in the past. Selecting the best topology in this “overlap” range requires an understanding of the tradeoffs associated with each topology.

Understanding Your Application

Before making any decision about UPS topology, it is important to understand the requirements of the equipment to be protected and the environment in which the UPS will be installed. Knowing these basic requirements is essential to an informed decision on the UPS topology that will best serve the application.

IT Equipment and AC power: The Switch-Mode Power Supply (SMPS)

Electricity is generally distributed as alternating current (AC) power from utilities and backup generators. AC voltage alternates between positive and negative — ideally as a perfect sine wave — passing through zero volts twice per cycle. It may not be noticeable to the naked eye, but a light bulb connected to utility voltage

¹ At very high power — 200,000VA and greater — a different debate focuses on the relative merits of **double-conversion on-line** vs. **delta-conversion on-line**. See APC White Paper #1, “The Different Types of UPS Systems,” for a comparison of these two on-line topologies.

actually flickers 100 or 120 times per second (for 50 or 60 cycle AC) as the voltage crosses zero to change polarity.

How does IT equipment use AC electricity to power its processing circuits? Does it also “turn off” 100 times or more per second as the line voltage changes polarity? Clearly, there is a problem here that IT equipment must solve. The way that virtually all modern IT equipment solves this problem is with a **Switch-Mode Power Supply (SMPS)**.² An SMPS first converts the AC voltage with all of its non-ideal components (voltage spikes, distortion, frequency variations, etc.) into flat DC (direct current). This process charges an energy storage element, called a **capacitor**, which stands between the AC input and the rest of the power supply. This capacitor is charged by the AC input in bursts twice per AC cycle when the sine wave is at or near its peaks (positive and negative) and discharges at whatever rate is required by the IT processing circuits downstream. The capacitor is designed to absorb these normal AC pulses along with anomalous voltage spikes continuously over its entire design life. So, unlike the flickering light bulb, IT equipment operates on a steady flow of DC instead of the pulsating AC of the utility grid.

This is not quite the end of the story. Microelectronic circuits require very low DC voltages (3.3V, 5V, 12V, etc.) but the voltage across the capacitor just mentioned can be as high as 400V. The SMPS also converts this high-voltage DC to tightly regulated low-voltage DC outputs.

In doing this voltage reduction, the SMPS performs another important function: it provides **galvanic isolation**. Galvanic isolation is a physical separation in the circuitry that serves two purposes. The first purpose is safety — protection against electric shock. The second purpose is protection against equipment damage or malfunction due to common-mode (ground-based) voltage or noise. Information about grounding and common-mode voltage is available in APC White Papers #9 (“Common Mode Susceptibility of Computers”) and #21 (“Neutral Wire Facts and Mythology”).

Figure 1 shows a piece of IT equipment (a server in this example) that is protected by a UPS. The internal components of the server, including the SMPS, are also shown.

Figure 1 – Typical UPS application: UPS and server

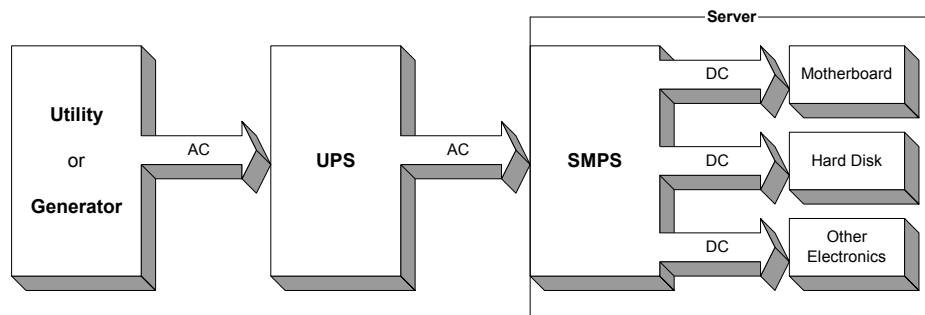

² “Switch-mode” refers to a feature of the power supply’s internal circuitry that is not related to this discussion.

In the same way the SMPS “rides through” the intervals between peaks of the AC input sine wave, it also rides through other anomalies and brief interruptions in the AC supply. This is a feature important to IT equipment manufacturers because they want their equipment to function even in cases where a UPS is not present. No IT equipment manufacturer wants to stake their reputation for quality and performance on a power supply that cannot endure even the slightest AC line anomaly. This is particularly true for higher-grade networking and computing equipment, which is therefore typically built with higher quality power supplies.

To demonstrate this ride-through ability, a typical computer power supply was heavily loaded and then its AC input was removed. The power supply’s output was monitored to determine how long acceptable output voltage continued to be delivered after the loss of AC input. The results are shown in Figure 2. The waveforms displayed are the power supply’s input voltage, input current, and DC output voltage.

Figure 2 – Power supply ride-through

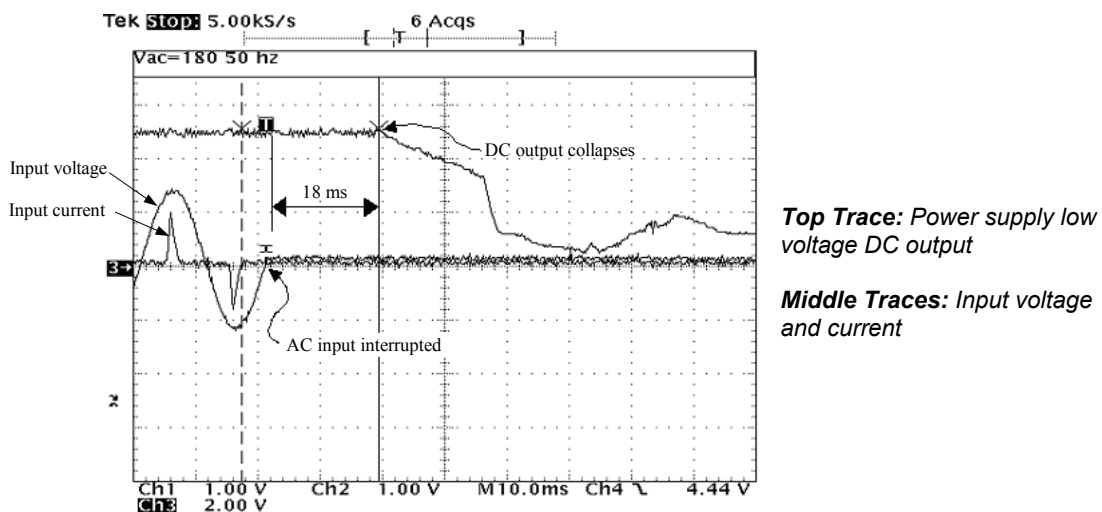

After the AC goes away, a heavily loaded computer power supply’s output collapses, but only after a significant delay.

Before being removed, the input *voltage* is the sine wave at the left in Figure 2. The input *current* — the spiked trace under the smooth voltage curve — consists of a short pulse at the positive peak of the input voltage and another short pulse at the negative peak. Only during these current pulses is the capacitor of the SMPS charged. The rest of the time, power is being drawn from the capacitor to provide power to the processing circuits.³ DC voltage at the output of the SMPS is the top trace in Figure 2. Notice that the output voltage remains tightly regulated for 18 milliseconds after the AC input is removed. APC has tested a variety of power supplies from different computer and other IT equipment manufacturers and found similar results. If the supplies are lightly loaded, the ride-through time will be much longer because the capacitor will be discharged more slowly.

³ Some SMPS perform power factor correction (PFC) — discussed later — and draw input current as a sine wave. They too have a high-voltage capacitor that performs the same ride-through function.

International Standards for UPS Compatibility With SMPS Loads

We have seen that an SMPS must ride through brief power disturbances just to be able to draw power from sinusoidal AC input voltage. But what does “brief” mean?

Figure 3 shows the specifications from IEC 62040-3, an international standard. It defines limits on the magnitude and duration of disturbances in the UPS output voltage that are acceptable to an SMPS load. As the shape of the shaded “comfort zone” shows, the smaller the magnitude of the transient, the longer it may be present in the UPS output. Note that this standard allows for the *continuous* presence of a rather wide range of voltage variations — nominal +10% to –20%. In other words, UPS output voltage can vary within that range for an indefinite length of time with no ill effect on SMPS operation; this is because similar standards for SMPS require ride-through over a range of input anomalies even broader than the range allowed for UPS output.⁴

Figure 3 – From IEC standard 62040-3: Magnitude and duration of acceptable AC voltage anomalies for compatibility with SMPS loads

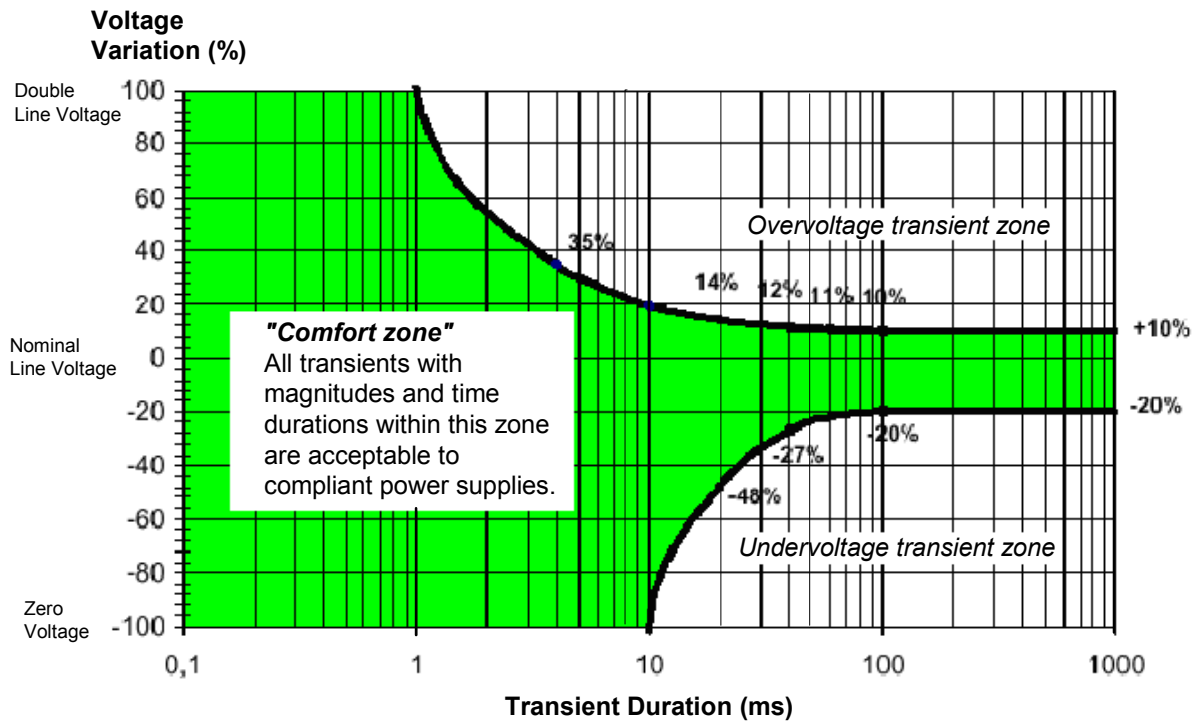

Voltage disturbances ("transients") whose magnitude and duration lie within the green "comfort zone" are allowed to be present in UPS output that is connected to SMPS equipment; all others are not.

⁴ The related SMPS standards, defining the range of anomalies an SMPS must accept are the "ITI/CBEMA curve" and IEC 61000-4-11.

Using Figure 3, the compatibility requirements for a UPS with 120V AC nominal output are as follows:

- For durations up to 1 millisecond, the UPS output voltage can go as high as 240V.
- For durations up to 10 milliseconds, the UPS output voltage can be zero!
- For durations up to 100 milliseconds, less severe swings (either up or down) can be present — allowable duration depends on the severity of the disturbance.
- For durations greater than 100 milliseconds (includes continuous operation), the UPS output voltage must remain between 96V and 132V.

In most areas of the world, except in some emerging-market countries, the power is relatively stable. On a typical day one might see voltages that vary, at the most, 5% above or below nominal — well within the allowable voltage variations shown in Figure 3. Because an SMPS can draw power from an AC source with these characteristics, it provides the ruggedness required to interface reliably with typical utility voltage.

In summary, SMPSs have the following advantages:

- They can accept wide variations in input voltage and frequency without degradation in performance.
- They have built-in galvanic isolation between their AC input and DC outputs, eliminating the need for upstream common-mode (neutral-to-ground) isolation.
- They can accept an appreciable amount of input voltage distortion without degradation in service life or reliability.
- They have a built-in “ride-through” time to tolerate brief power interruptions.

Myth vs. Reality

MYTH: Zero UPS transfer time is required by mission-critical equipment — for example, to prevent lock-up and/or packet loss in network switches.

REALITY: SMPSs are the power supplies found in virtually all mission-critical equipment. They must have a “ride-through” time of 10 milliseconds or more to comply with international standards (see Figure 3). Any electronic equipment that cannot sustain such a ride-through time is generally considered to be of inferior design or extremely rare — most likely a specialized application (i.e. not computer or IT equipment).

Understanding Your UPS Options

APC White Paper #1, “The Different Types of UPS Systems,” describes the following five main UPS topologies in use today along with their performance characteristics:

- Standby
- Line-interactive
- Standby-ferro
- Double-conversion on-line
- Delta-conversion on-line

In the power range of 750VA to 5000VA, nearly all UPSs sold for use in today's IT applications are either line-interactive or double-conversion on-line. Other topologies are uncommon in this range for reasons beyond the scope of this paper.

Line-interactive UPS

A **line-interactive** UPS conditions and regulates the AC power from the utility, generally using only one main power converter. Figure 4 shows the standard description of this topology from IEC standard 62040-3.

Figure 4 – Line-interactive UPS topology, from IEC 62040-3 block diagram showing a power interface and one main conversion block

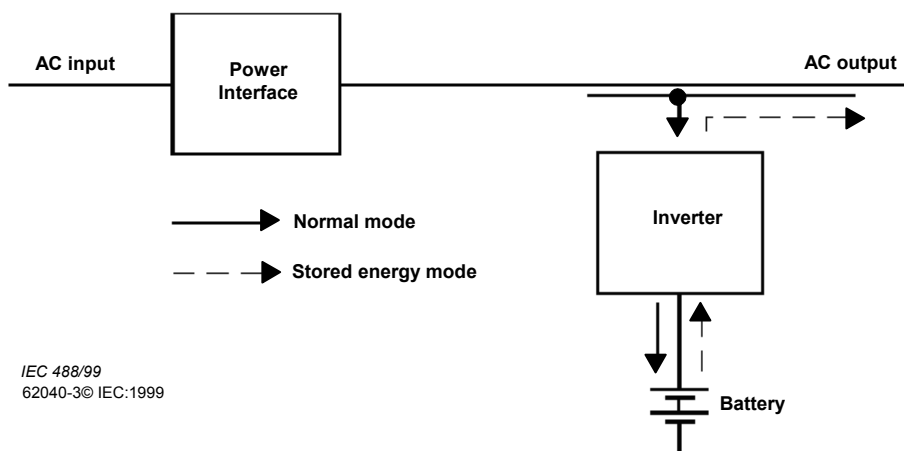

When AC input is present, the “power interface” block in Figure 4 filters the AC power, suppresses voltage spikes, and provides sufficient voltage regulation to operate well within the specifications discussed earlier. This is most often accomplished with passive filter components and a tap-changing transformer. The main power converter (the “inverter” block) redirects some of the input AC power to keep the batteries fully charged while the AC line voltage is present. This typically requires less than 10% of the UPS power rating, so the components stay cool while in this mode of operation. For example, the inverter block in a 3000-watt line-interactive UPS operates at only 300 watts (1/10th of its capacity) or less while charging its batteries. Many components sized for full load operation can run just above the outside ambient temperature when AC is present — the most common mode of operation. When the AC line voltage falls outside the input range of the power interface, the inverter supplies AC output with power from the battery. The input voltage range of the power interface is usually a fixed window, typically -30% to +15% of nominal. For example, a line-interactive UPS with 120V nominal output voltage will keep its output between 107V and 127V while the input varies from 84V to 138V.

A subtle but important fact about line-interactive UPS operation is that while it filters and conditions the voltage being supplied to the load, it does not alter the wave-shape of the current being drawn by the load.

Therefore, if the load has an SMPS with power factor correction (PFC),⁵ the line-interactive UPS will not distort or interfere with the power factor correction. If the load SMPS does *not* have power factor correction and draws its current in peaks (as shown in Figure 2), the line-interactive UPS will not alter or “correct” this waveform either.

Theoretically, the small number of components and the cool operation of the main power converter (the “inverter” block in Figure 4) both contribute to long life and high reliability. In practice, however, reliability is usually determined by other factors as described in the later section [Reliability Considerations](#).

With its low cost and durability, the line-interactive UPS has been used successfully in millions of IT installations worldwide.

Things to Consider (Line-interactive):

In developing countries or other infrastructure-challenged areas where the AC line voltage is unstable, fluctuates wildly, or is highly distorted, a line-interactive UPS may go to battery once or twice a day or even more frequently. This is because the line-interactive design has a somewhat limited ability to keep large voltage swings and heavy distortion from reaching the load unless it disconnects from the AC supply and transfers to battery power. Even though the line-interactive UPS will provide an output voltage within the IEC limits (Figure 3) for as long as battery power is available, frequent use of the battery will reduce its capacity, leaving less run-time available for an extended outage. Also, even if the batteries are not discharged to exhaustion, frequent use can result in the batteries needing to be replaced more often.

Advantages of line-interactive topology:

- Lower electricity consumption (less costly to operate) – More efficient because less power conversion is performed when acceptable AC input is present.
- Theoretically higher reliability – Lower component count and lower operating temperatures. (See later section [Reliability Considerations](#).)
- Less heat load on the facility – Less heat is produced by the UPS.

Things to watch out for:

The line-interactive UPS may not be the appropriate choice for installations where

- AC power is unstable or highly distorted, because battery power will be used too often to keep the UPS output within specifications.
- Power Factor Correction (PFC) is required and the load equipment does not perform this function.

Myth vs. Reality

MYTH: Line-interactive UPSs do not condition power – noise and spikes get through that wear out power supplies.

REALITY: High-quality line-interactive units have powerful built-in surge and noise suppression to keep their output within acceptable levels so that the load’s reliability is not affected.

⁵ A device with power factor correction (PFC) draws current from AC input as a smooth sine wave rather than in pulses. See Figure 2 for an illustration of non-PFC output.

Double-conversion On-line UPS

As its name implies, a **double-conversion on-line** UPS converts power twice. First, AC input, with all of its voltage spikes, distortion, and other anomalies, is converted into DC. This is very similar to the operation of the SMPS in IT equipment, as described earlier. And, like the SMPS, a double-conversion on-line UPS uses a capacitor to stabilize this DC voltage and store energy drawn from the AC input. Second, DC is converted back into AC that is tightly regulated by the UPS. This AC output can even have a different frequency from the AC input — something not possible with a line-interactive UPS. All of the power provided to the load equipment goes through this double-conversion process when AC input is present.

When AC input goes out of a specified range, the UPS draws power from its battery so that the UPS output is not affected. In many double-conversion on-line designs, this transition inside the UPS between AC input and battery takes several milliseconds. Again, it is the capacitor in the “DC link” (see Figure 5) that provides stored energy to the inverter during these transitions. So, even though there is a brief interruption in power going into the “DC link,” the UPS output voltage is unaffected and continuous.

In modern designs, an additional battery-charging circuit is almost always included in the topology, so a double-conversion on-line UPS typically has at least three power conversion stages. Figure 5 illustrates this topology based on IEC standard 62040-3.

Figure 5 – Double-conversion on-line UPS topology, from IEC 62040-3 block diagram showing four converter blocks

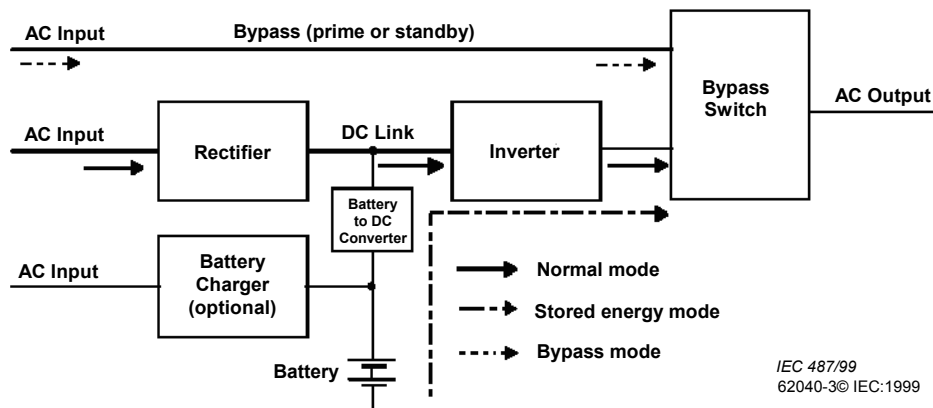

In addition to performing AC-to-DC conversion, the rectifier section also provides power factor correction (PFC), which means it draws current from the AC line as a smooth sine wave rather than in pulses (see Figure 2 for an illustration of non-PFC input current). Because PFC “corrects” the input current waveform, less current is drawn — including reductions in high-frequency harmonics. This happens even if the IT equipment being powered by the UPS draws current in a pulsed (non-PFC) fashion. See APC White Paper #26, “Hazards of Harmonics and Neutral Overloads,” for more about power factor correction and neutral harmonics.

When operating at full load, the range of acceptable AC input voltage of a double-conversion on-line is similar to that of a line-interactive. Unlike a line-interactive, however, a double-conversion on-line can operate with much lower input voltage if the UPS is not fully loaded. For a typical 120V double-conversion UPS, this means it might be able to operate from AC power at very light loads even if the input voltage is as low as 50% of nominal (60V). While this is an interesting attribute of the on-line topology, it is rarely useful (other than for demonstration) because extended disturbances of this magnitude are extremely rare and because load conditions, in practice, are variable.

An on-line UPS is usually smaller than a line-interactive UPS for any given power capacity. Even though it has more components (typically three times as many), the components are smaller. This is especially true for higher power units above 2200VA and is always true comparing against a run-time extendable line-interactive UPS.

On-line topology usually includes a bypass circuit that is used if there is an extended overload or if there is a problem in one of the double-conversion circuits. Transitions between bypass and inverter operation often drop the output for a few milliseconds, similar to a line-interactive UPS transferring to battery. As a result, many on-line units rely on the SMPS to ride through these disturbances to the UPS output. As with line-interactive units, this does not present a problem as long as the UPS output disruption is within the specifications shown in Figure 3.

Things to Consider (Double-conversion On-line)

The on-line power conversion stages, which run continuously to provide the tightly regulated output voltage for which they are known, can carry loads up to their full power rating. There are, however, costs associated with this increased performance.

Due to its multiple power stages, a typical double-conversion on-line UPS will have many more components than a typical line-interactive UPS. Because these components are continuously processing all of the power drawn by the load equipment, their temperatures are typically higher than the components in a line-interactive UPS when AC input is present.

Theoretically, both constant operation and higher temperatures reduce the reliability of the components in the UPS. In practice, however, reliability is often determined by other factors as described below under [Reliability Considerations](#).

Another factor to consider is the additional energy needed to operate a double-conversion on-line UPS over time. A double-conversion on-line UPS continuously operates with efficiency between 85% and 92%, depending on the particular design, compared to 96% to 98% for a line-interactive UPS. A 90% efficient 1000W UPS for example, fully loaded, will consume 100W of power continuously. This translates into roughly \$100 per year in additional utility costs (on average). In addition to the utility costs, this 100W of

Myth vs. Reality

MYTH: On-line UPSs offer better protection against Common-Mode (CM) noise.

REALITY: Even though it is possible to design both on-line and line-interactive topologies with galvanic isolation, they both typically use passive components to *reduce* CM voltage. Neither on-line nor line-interactive topology offers a fundamental advantage in this respect. SMPSs already have galvanic isolation, so external isolation is unnecessary. See APC White Papers #9 and #21 for more information.

heat must be removed from the environment, incurring additional cooling costs that will vary depending on the particular cooling system's efficiency. This may not seem like a lot, but when considering the sum of all losses over many UPSs across an enterprise, or even the total lifetime energy consumption of a single UPS, it becomes a significant factor in the UPS total cost of ownership. In comparison, a similarly loaded line-interactive UPS will incur less than a third as much energy cost per load power.

Advantages of double-conversion on-line:

- Operates less often from battery when the input voltage is highly distorted or wildly fluctuating
- Power factor correction (PFC) provided, regardless of load type
- More compact and lightweight, especially at higher power levels
- Can regulate output frequency, and even perform frequency "conversion" from 50Hz to 60Hz (and vice versa)

It could be argued that tightly regulated AC output voltage is an *advantage* of the on-line topology. However, an SMPS does not need tightly regulated AC due to the voltage regulation provided by the SMPS itself, as described earlier in this paper.

Things to watch out for:

- Double-conversion on-line contains more components that run continuously at higher temperatures and, with all other things being equal, have less service life than similar parts found in line-interactive.
- Double-conversion on-line uses more electricity than line-interactive because it is continuously converting and reconverts power from the input to the output when AC input is present.
- Double-conversion on-line creates more heat that is released into the IT environment. This heat must be effectively removed to reduce life-degrading effects on other systems and even on the UPS' own batteries.

Reliability Considerations

In both topologies, certain aspects of the designs theoretically increase or decrease operating life and reliability. For line-interactive, the small number of components and cool operation of the main power stage both tend to *increase* operating life and reliability. For double-conversion on-line, constant operation and higher operating temperatures both tend to *decrease* operating life and reliability.

In practice, however, reliability is generally determined by how well the manufacturer designs and builds the UPS and by the quality of the components used, regardless of topology. Because quality is vendor-dependent, there can be high quality double-conversion on-line designs and poor quality line-interactive designs, and vice versa.

Myth vs. Reality

MYTH: Tighter voltage regulation improves performance and reliability of IT equipment.

REALITY: All SMPSs convert AC input voltage (with its spikes and distortion) into steady DC. This DC is then used to create clean, well-regulated DC output for all IT loads. Input line conditions within their rated ranges do NOT affect the quality of the SMPS outputs or the performance of the IT equipment. Otherwise, why would an SMPS have this range printed on its chassis?

Comparison Summary

The following table summarizes the important advantages and disadvantages of line-interactive and double-conversion on-line UPS topologies.

Table 1 – Comparison of line-interactive and double-conversion on-line topologies

TOPOLOGY	Reliability	Total Cost of Ownership	Input	Output	Size / weight
Line-interactive	<p>+</p> <p>Fewer parts</p> <p>Lower operating temperature</p>	<p>+</p> <p>Lower initial cost (fewer parts)</p> <p>Lower operating cost (less electricity)</p>	<p>-</p> <p>No PFC</p> <p>Extreme voltage distortion can require frequent battery usage</p>	<p>+ / -</p> <p>Output frequency varies within a configurable range</p>	<p>-</p> <p>Typically larger/heavier</p>
Double-conversion On-line	<p>-</p> <p>Many parts</p> <p>Higher operating temperature</p>	<p>-</p> <p>Higher initial cost (more parts)</p> <p>Higher operating cost (electricity and cooling)</p>	<p>+</p> <p>Has PFC</p> <p>Accepts extreme voltage distortion without going to battery</p>	<p>+</p> <p>Output fixed to a configurable frequency</p>	<p>+</p> <p>Typically smaller/lighter, especially at higher power levels</p>

Conclusions

In the power range between 750VA and 5000VA, both types of UPS adequately protect IT equipment from power disturbances, so the decision for which topology to use is primarily based on the specifics of the customer application.

Because initial cost, operating expense, heat generation, and reliability are primary concerns in any application, it would appear the default choice should be line-interactive. Line-interactive has, in fact, become the efficient and reliable workhorse of the typical IT environment.

Under certain circumstances, however, double-conversion on-line can be the better choice. In particular, in geographic areas where the AC power is highly distorted and/or has extreme voltage variations, a double-conversion on-line UPS will go to battery less often to maintain proper output. Less battery usage preserves battery capacity for extended outages, and preserves battery service life. In addition, reducing battery replacement cost can offset the advantage of the lower initial and operating costs of a line-interactive UPS. Other less common situations that might call for a double-conversion on-line UPS are those that require power factor correction (PFC), small physical size, or frequency conversion, such as some types of medical equipment or instrumentation.

About the Authors

Jeffrey Samstad is Chief Engineer of the Smart-UPS RT product line at American Power Conversion. He has a Bachelors degree in Electrical Engineering and 14 years of experience leading UPS design teams and working with various UPS architectures.

Michael Hoff has a Masters degree in Electrical Engineering, Power Systems, from Northeastern University and leads a New Technology Research group for American Power Conversion. During his 16 years at APC he has developed uninterruptible power supplies and UPS architectures, and has managed product development projects, teams, and groups in the US and abroad.